

Podkładka okrągła do konstrukcji drewnianych / Round washers for wood constructions

Norma
Standart

DIN 440

ISO 7094
PN 82019

Zakres / Range $\varnothing 5,5 \div \varnothing 56$

Zakres twardości / Hardness range - 100HV, 200HV

Materiał / Material Stal, Stal nierdzewna, metale nieżelazne
Steel, stainless steel, non-ferrous metals

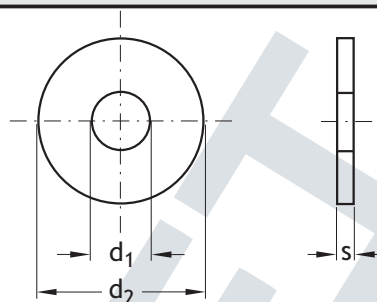

Pod gwint / thread dia.	M 5	M 6	M 7	M 8	M 10	M 12	M 14
d_1	5,5	6,6	7,6	9	11	13,5	15,5
d_2	18	22	24	28	34	44	50
s_{nom}	2	2	2	3	3	4	4

Pod gwint / thread dia.	M 16	M 18	M 20	M 22	M 24	M 27	M 30
d_1	17,5	20	22	24	26	30	33
d_2	56	60	72	80	85	98	105
s_{nom}	5	5	6	6	6	6	6

Pod gwint / thread dia.	M 33	M 36	M 39	M 42	M 45	M 48	M 52
d_1	36	39	42	45	48	52	56
d_2	115	125	140	150	160	170	180
s_{nom}	8	8	10	8	8	10	10

Przykład oznaczania podkładki okrągłej do konstrukcji drewnianej o wielkości nominalnej 11 i twardości 100 HV

Podkładka DIN 440 - 11 - 100HV

Example designation round washer for wood constructions, nominal size 11 and hardness 100 HV

Washer DIN 440 - 11 - 100HV

1/1

